

Осмотровые каналы  
Service pits

ukázka konkrétní realizace

na stavbě včetně stavební připravenosti



# ukázka stavební připravenosti – provedení výkopu

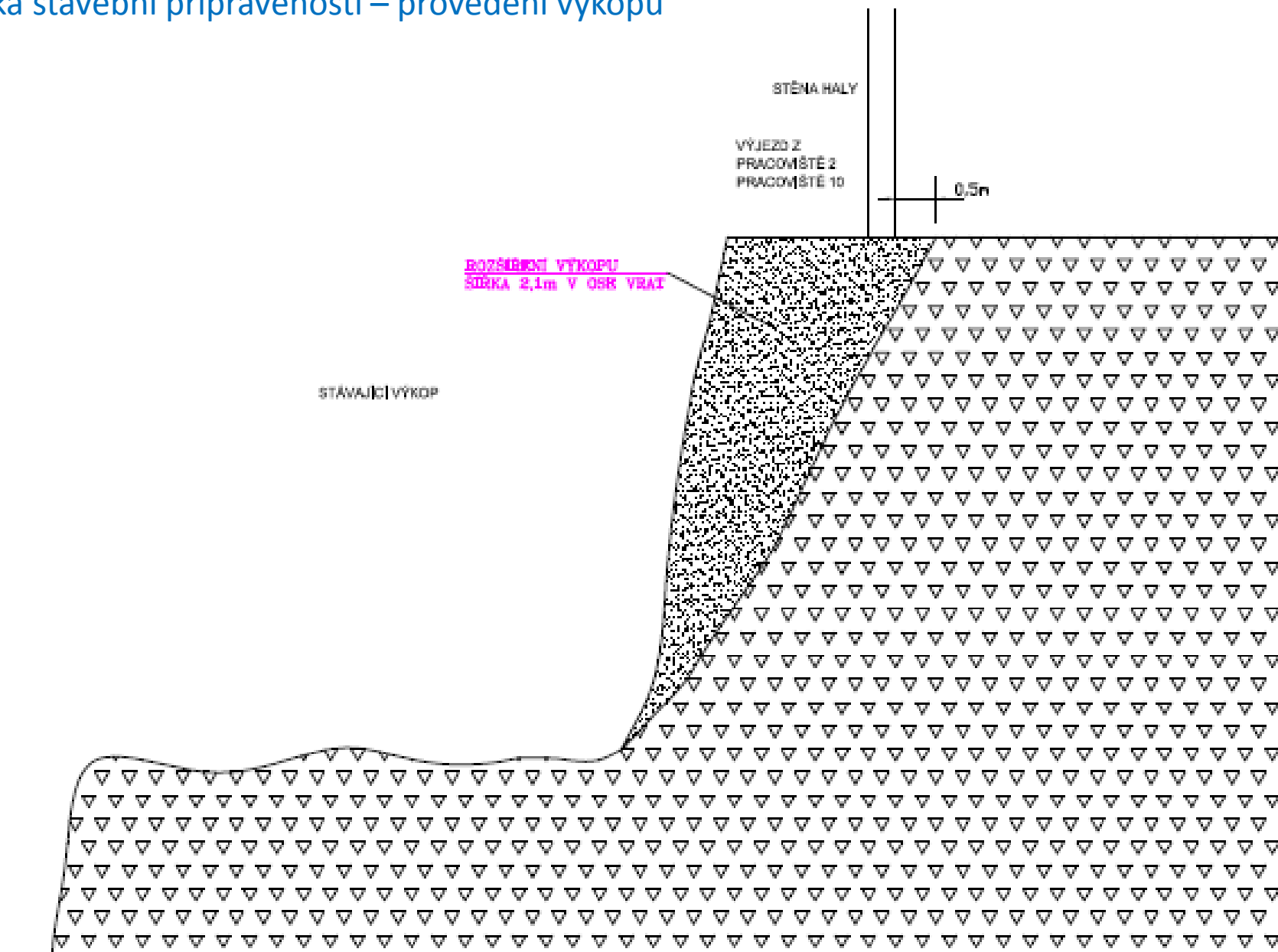

# ukázka stavební připravenosti – příprava základové desky

B

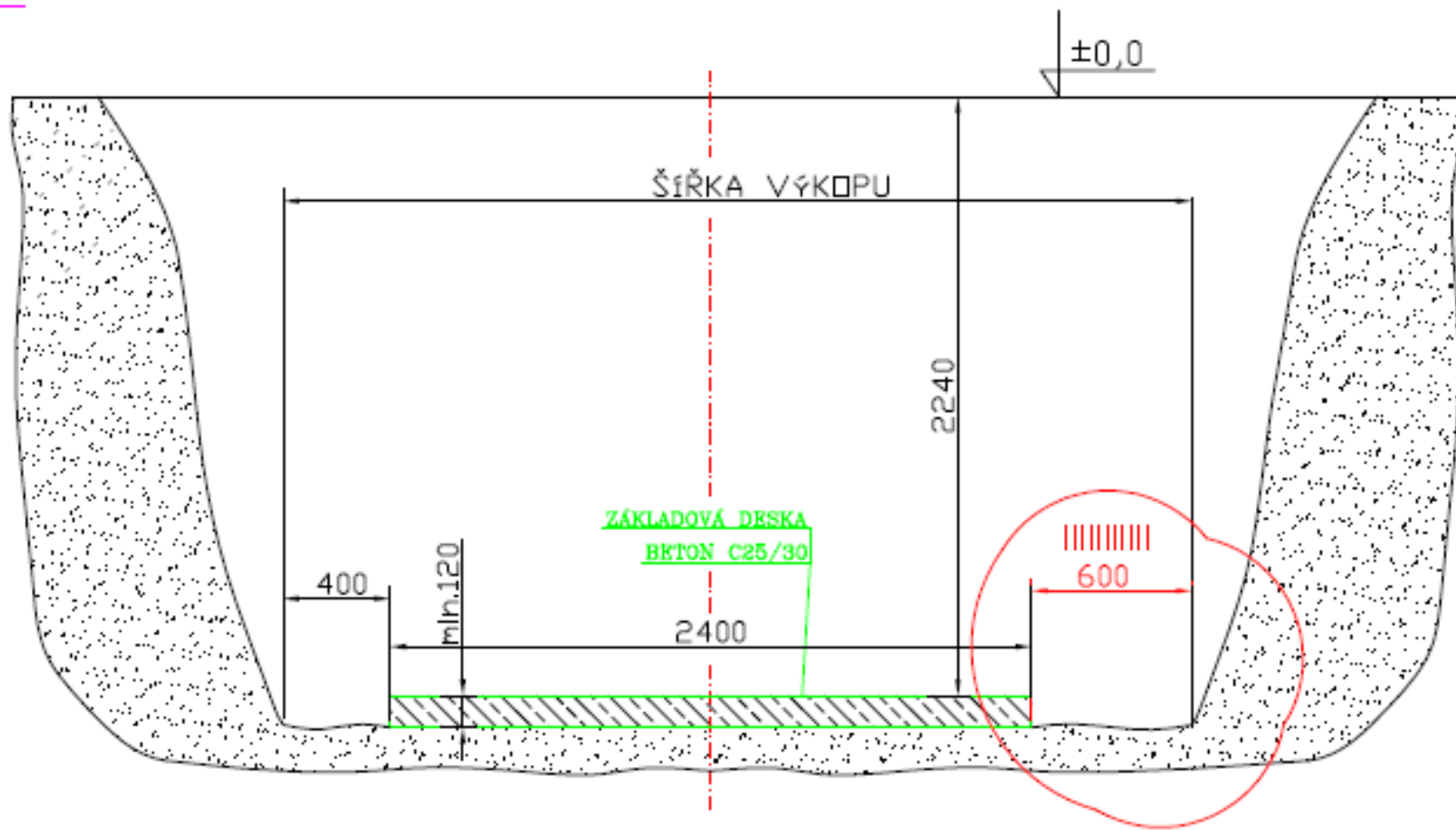

ukázka stavební připravenosti – usazení jámy na základovou desku

B-

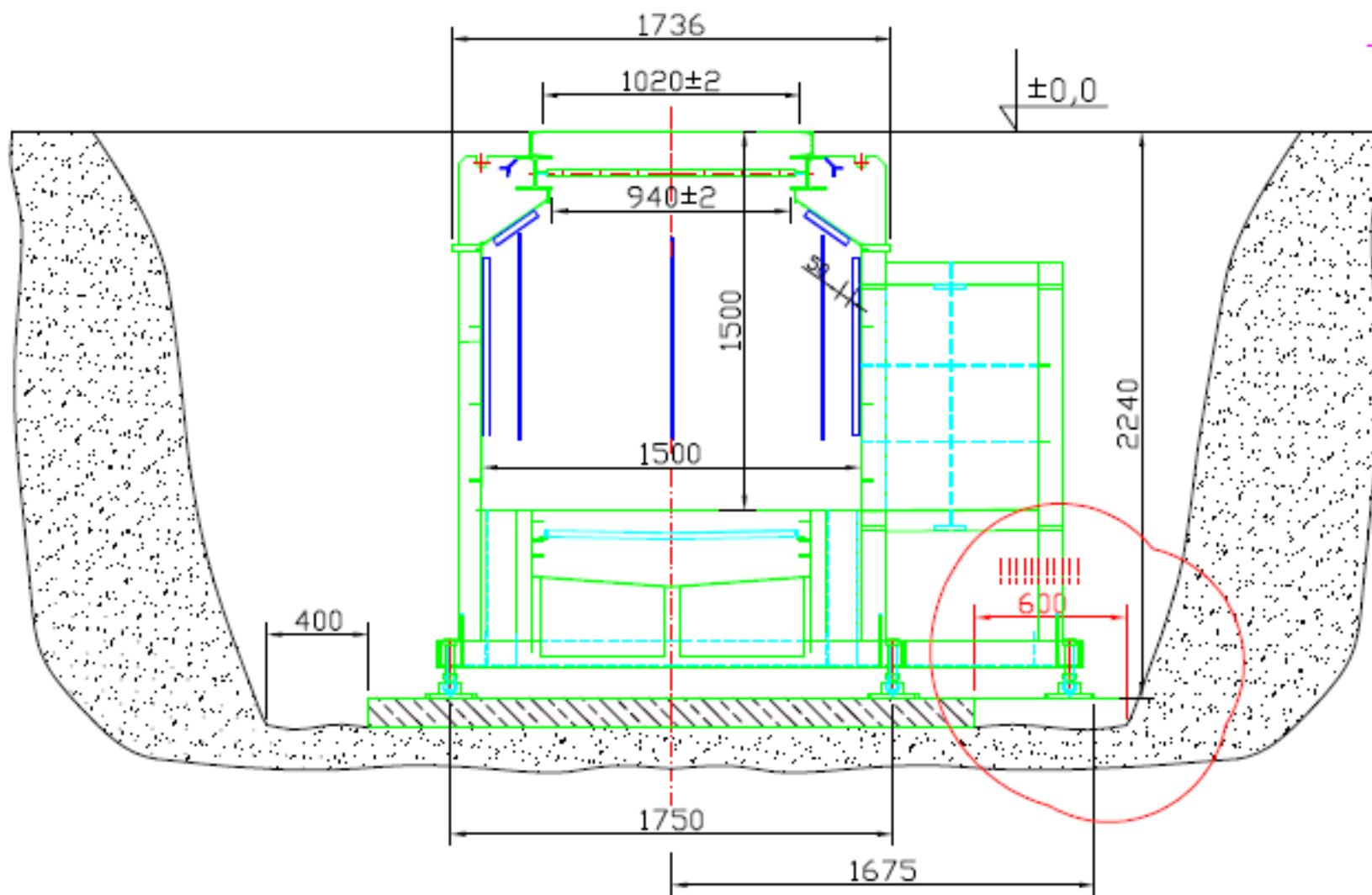



# ukázka stavební připravenosti – schéma základové desky

